

RS232C QUAD LINE DRIVER

- CURRENT LIMITED OUTPUT $\pm 10\text{mA}$ TYP.
- POWER-OFF SOURCE IMPEDANCE 300Ω MIN.
- SIMPLE SLEW RATE CONTROL WITH EXTERNAL CAPACITOR
- FLEXIBLE OPERATING SUPPLY RANGE
- INPUTS ARE TTL AND μP COMPATIBLE

DESCRIPTION

The MC1488 is a monolithic quad line driver designed to interface data terminal equipment with data communications equipment in conformance

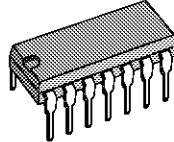

N
DIP14
(Plastic Package)

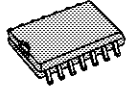

D
SO14
(Plastic Micropackage)

ORDER CODES : MC1488P (Plastic DIP)
MC1488L (Ceramic DIP)
MC1488D (SO14)

PIN CONNECTIONS (top view)

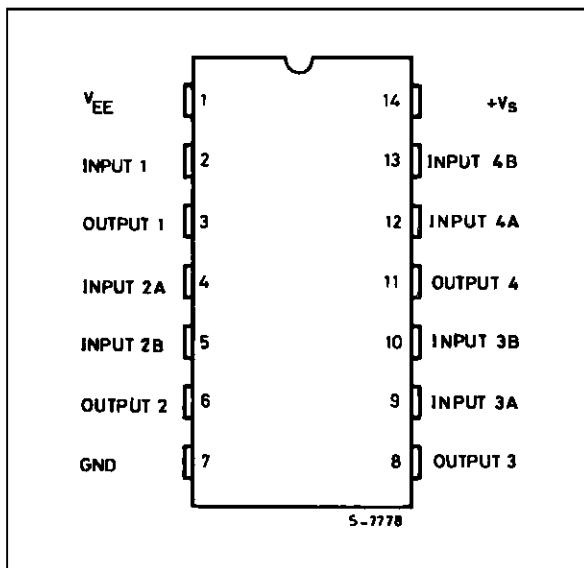

LOGIC DIAGRAM

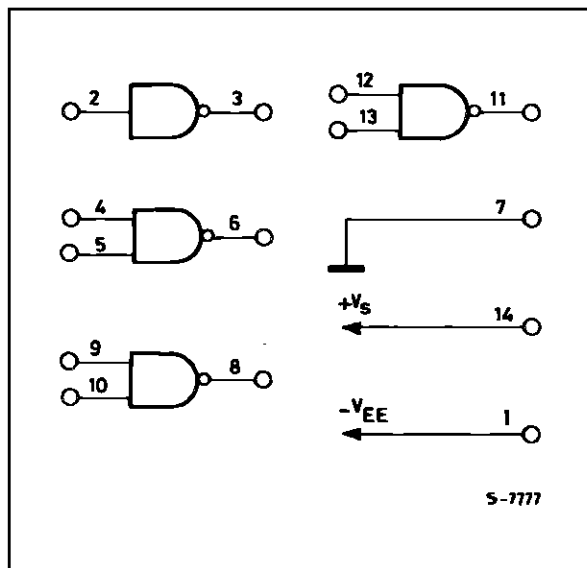

ABSOLUTE MAXIMUM RATINGS

Symbol	Parameter	Test Conditions	Unit
V _S	Power Supply Voltage	15	V
V _{EE}	Power Supply Voltage	-15	V
V _{IR}	Input Voltage Range	-15 ≤ V _{IR} ≤ 7	V
V _O	Output Signal Voltage	±15	V
T _{amb}	Operating Ambient Temperature	0 to 75	°C
T _{stg}	Storage Temperature Range	-65 to 150	°C

THERMAL DATA

Symbol	Parameter	Plastic DIP14	Ceramic DIP14	SO14
R _{th j-amb}	Thermal Resistance Junction-ambient Max.	200°C/W	165°C/W	165°C/W

ELECTRICAL CHARACTERISTICS

V_S = 9 ±10%V, V_{EE} = -9 ±10%V, T_{amb} = 0 to 75°C, unless otherwise specified

Symbol	Parameter	Test Conditions	Min.	Typ.	Max.	Unit	Fig.
I _{IL}	Input Current	Low Logic State V _{IL} = 0V		1	1.6	mA	1
I _{IH}	Input Current	High Logic State V _{IH} = 5V			10	µA	1
V _{OH}	Output Voltage	High Logic State R _L = 3kΩ V _{IL} = 0.8V, V _S = 9V, V _{EE} = -9V V _{IL} = 0.8V, V _S = 13.2V, V _{EE} = -13.2V	6 9	7 10.5		V	2 2
V _{OL}	Output Voltage	Low Logic State V _{IH} = 1.9V, V _{EE} = -9V, V _S = 9V V _{IH} = 1.9V, V _{EE} = -13.2V, V _S = 13.2V	-6 -9	-7 -10.5		V	2 2
I _{OS⁺}	Positive Output Short-circuit Current		6	10	12	mA	3
I _{OS⁻}	Negative Output Short-circuit Current		-6	-10	-12	mA	3
R _O	Output Resistance	V _S = V _{EE} = 0 V _{OL} = ±2V	300			Ω	4
I _S	Positive Supply Current (R _I = ∞)	V _{IH} = 1.9V V _S = 9V V _{IL} = 0.8V V _S = 9V V _{IH} = 1.9V V _S = 12V V _{IL} = 0.8V V _S = 12V V _{IH} = 1.9V V _S = 15V V _{IL} = 0.8V V _S = 15V		15 4.5 19 5.5	20 6 25 7 34 12	mA	5
I _{EE}	Negative Supply Current (R _L = ∞)	V _{IH} = 1.9V V _S = -9V V _{IL} = 0.8V V _S = -9V V _{IH} = 1.9V V _S = -12V V _{IL} = 0.8V V _S = -12V V _{IH} = 1.9V V _S = -15V V _{IL} = 0.8V V _S = -15V		-13 -18	-17 -15 -23 -15 -34 -2.5	mA µA mA µA mA mA	5
P _C	Power Consumption	V _S = 9V V _{EE} = -9V V _S = 12V V _{EE} = -12V			333 567	mW	

SWITCHING CHARACTERISTICS

V_S = ±9 ±1V, V_{EE} = -9 ±1%V, T_{amb} = 25°C

Symbol	Parameter	Test Conditions	Min.	Typ.	Max.	Unit	Fig.
t _{PHL}	Propagation Delay Time	Z _i = 3kΩ and 15pF		275	350	ns	6
t _{THL}	Fall Time	Z _i = 3kΩ and 15pF		45	75	ns	6
t _{PHL}	Propagation Delay Time	Z _i = 3kΩ and 15pF		110	175	ns	6
t _{THL}	Rise Time	Z _i = 3kΩ and 15pF		55	100	ns	6

* Maximum package power dissipation may be exceeded if all outputs are shorted simultaneously.

TEST CIRCUITS

Figure 1 : Input Current

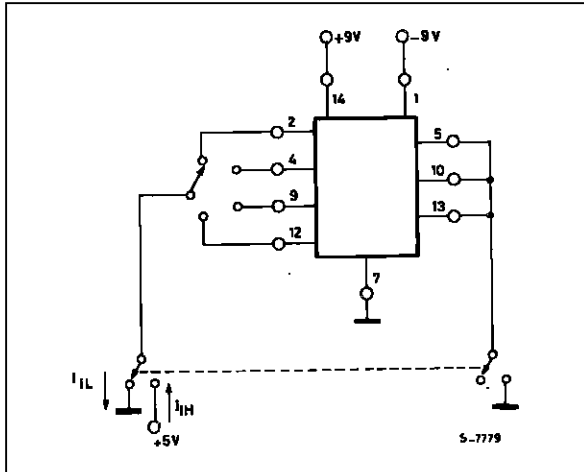

Figure 2 : Output Voltage

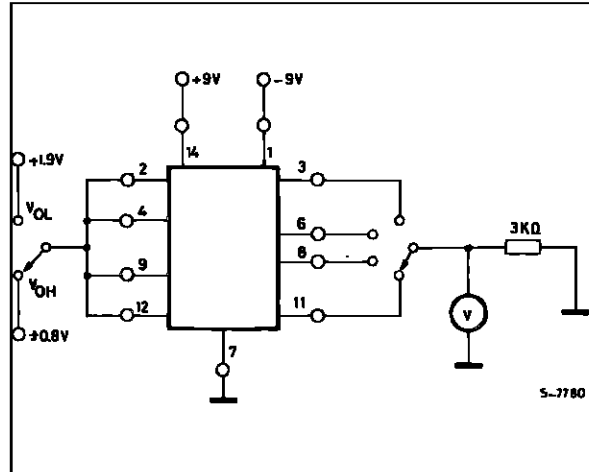

Figure 3 : Output Short-Circuit Current

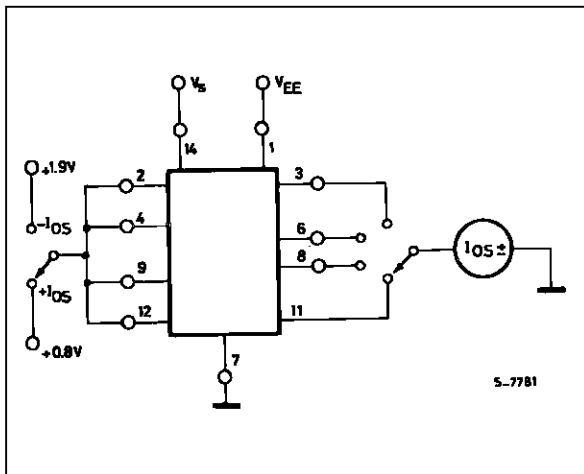

Figure 4 : Output Resistance (power off)

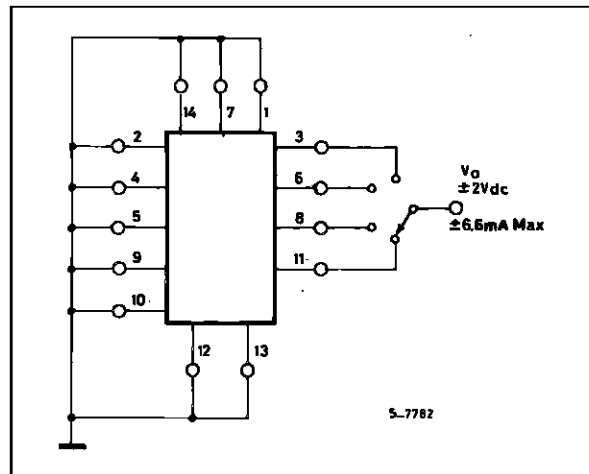

Figure 5 : Power Supply Currents

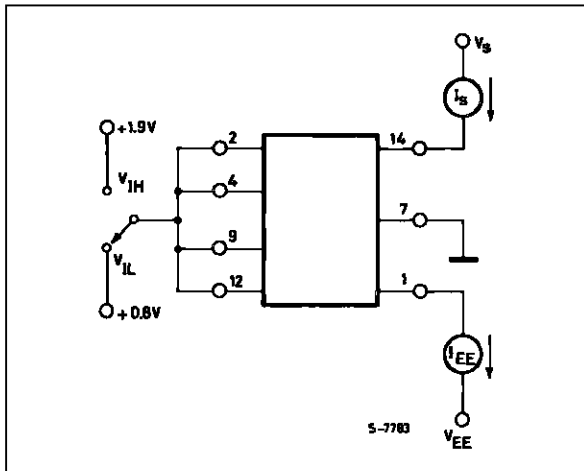

Figure 6 : Switching Response

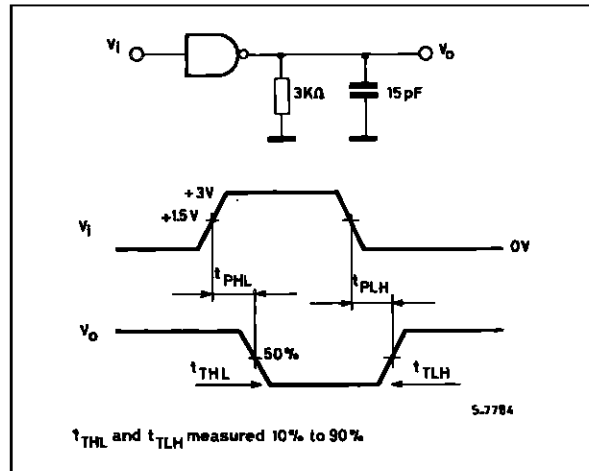

Figure 7 : Transfer Characteristics versus Power Supply Voltage

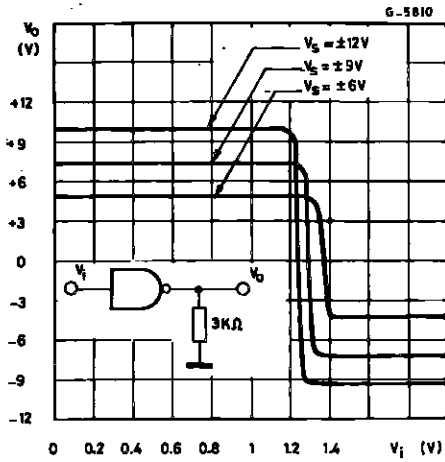

Figure 8 : Short-Circuit Output Current versus Temperature

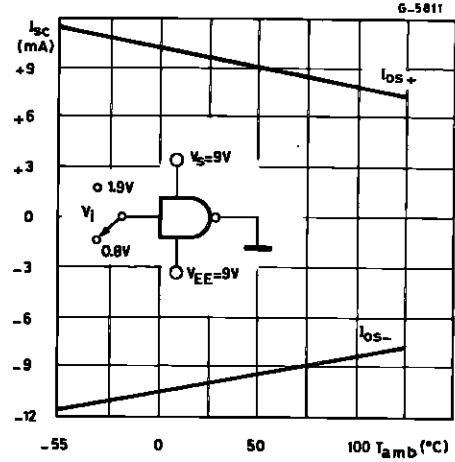

Figure 9 : Output Slew-Rate Load Capacitance

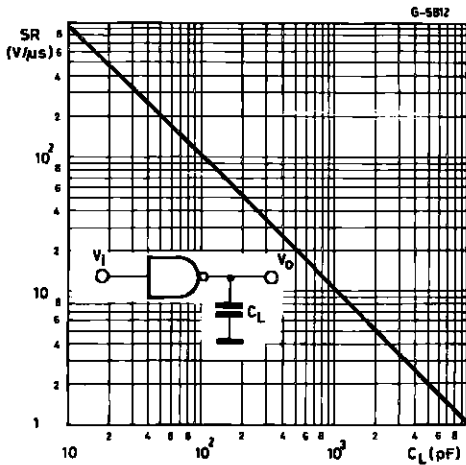

Figure 10 : Output Voltage and Current Limiting Characteristics

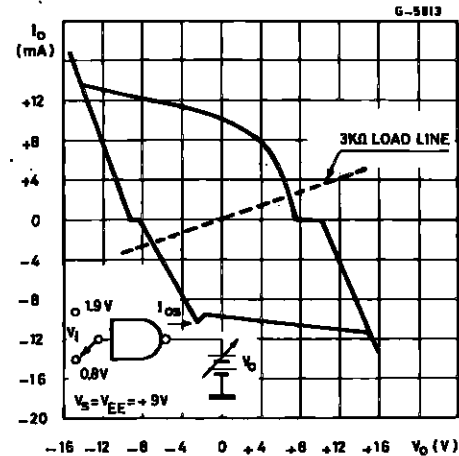
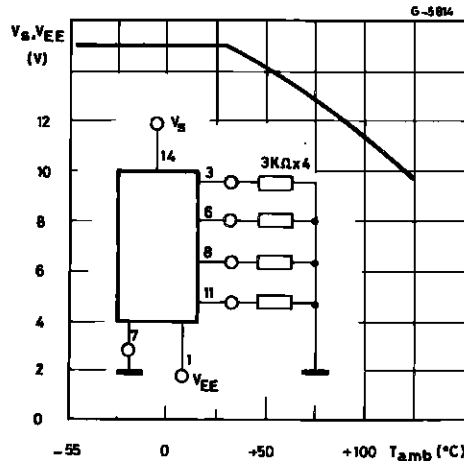
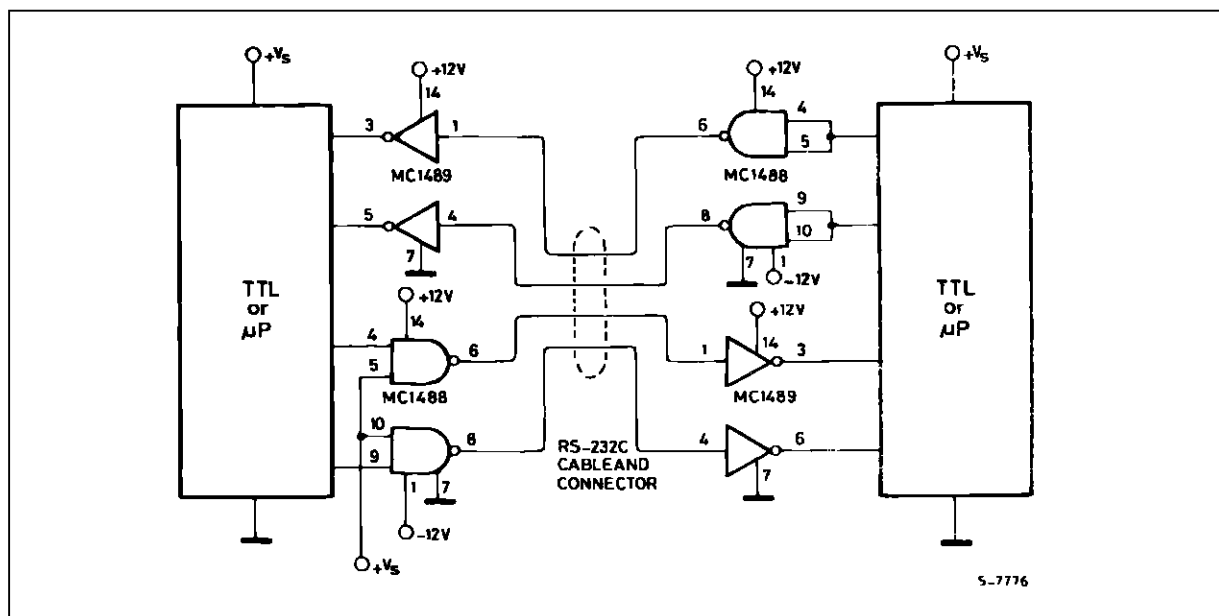

Figure 11 : Maximum Operating Temperature versus Power Supply Voltage



TYPICAL APPLICATION : RS232C Data Transmission



APPLICATION INFORMATION

The Electronic Industries Association (EIA) has released the RS232C specification detailing the requirements for the interface between data processing equipment. This standard specifies not only the number and type of interface leads, but also the voltage levels to be used. The MC1488 quad driver and its companion circuit, the MC1489 quad receiver, provide a complete interface system between DTL or TTL logic levels and the RS232C defined levels. The RS232C requirements as applied to drivers are discussed herein.

The required driver voltages are defined as between 5 and 15 V in magnitude and are positive for a logic "0" and negative for a logic "1". These voltages are so defined when the drivers are terminated with a 3000 to 7000 Ω resistor. The MC1488 meets this voltage requirement by converting a DTL/TTL logic level into RS232C levels with one stage of inversion.

The RS232C specification further requires that during transitions, the driver output slew rate must not exceed 30 V per μ s. The inherent slew rate of the MC1488 is much too fast for this requirement. The current limited output of the device can be used to control this slew rate by connecting a capacitor to each driver output. The required capacitor can be easily determined by using the relationship $C = I_{OS} \times \Delta T / \Delta V$ from which Figure 12 is derived. Accordingly, a 330 pF capacitor on each output will guarantee a worst case slew rate of 30 V per μ s.

The interface driver is also required to withstand an accidental short to any other conductor in an interconnecting cable. The worst possible signal on any conductor would be another driver using a plus or minus 15 V, 500 mA source. The MC1488 is designed to indefinitely withstand such a short to all four outputs in a package as long as the power-supply voltages are greater than 9.0 V (i.e., $V_{S} \geq 9.0$ V ; $V_{EE} \leq -9.0$ V). In some power-supply designs, a loss of system power causes a low impedance on the power-supply outputs. When this occurs, a low impedance to ground would exist at the power inputs to the MC1488 effectively shorting the 300 Ω output resistor to ground. If **all four outputs** were then shorted to plus or minus 15 V, the power dissipation in these resistors would be excessive. Therefore, if the system is designed to permit low impedances to ground at the power-supplies of the drivers, a diode should be placed in each power-supply lead to prevent over-heating in this fault condition. These two diodes, as shown in Figure 13, could be used to decouple all the driver packages in a system. (These same diodes will allow the MC1488 to withstand momentary shorts to the ± 15 V limits specified in the earlier Standard RS232B). The addition of the diodes also permits the MC1488 to withstand faults with power-supplies of less than the 9.0 V stated above.

The maximum short-circuit current allowable under fault conditions is more than guaranteed by the previously mentioned 10 mA output current limiting.

Figure 12 : Slew Rate versus Capacitance for $I_{SC} = 10\text{mA}$

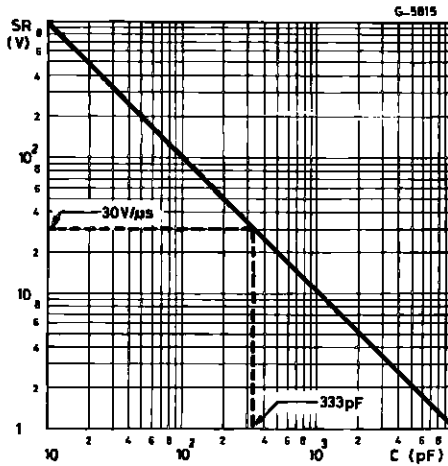
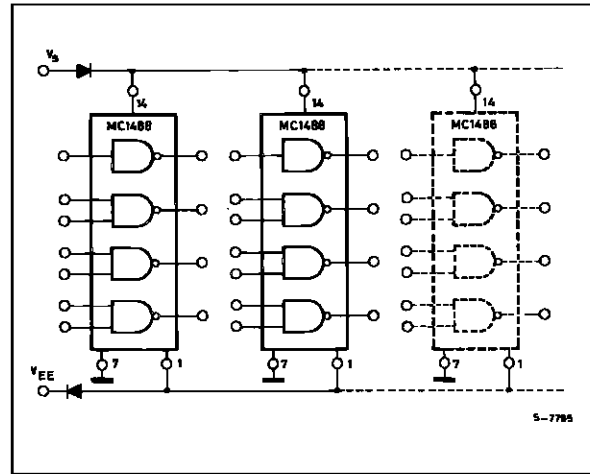

Figure 13 : Power Supply Protection to Meet Power-off Fault Conditions



OTHER APPLICATION

The MC1488 is an extremely versatile line driver with a myriad of possible applications. Several features of the drivers enhance this versatility :

1. Output Current Limiting - this enables the circuit designer to define the output voltage levels independent of power-supplies and can be accomplished by diode clamping of the output pins.
2. Power-Supply Range - as can be seen from the schematic drawing of the drivers, the positive and negative driving elements of the device are essentially independent and do not require matching

power-supplies. In fact, the positive supply can vary from a minimum seven volts (required for driving the negative pulldown section) to the maximum specified 15 V. The negative supply can vary from approximately - 2.5 V to the minimum specified - 15 V. The MC1488 will drive the output to within 2 V of the positive or negative supplies as long as the current output limits are not exceeded. The combination of the current-limiting and supply-voltage features allow a wide combination of possible outputs within the same quad package.

DIP14 PACKAGE MECHANICAL DATA

DIM.	mm			inch		
	MIN.	TYP.	MAX.	MIN.	TYP.	MAX.
a1	0.51			0.020		
B	1.39		1.65	0.055		0.065
b		0.5			0.020	
b1		0.25			0.010	
D			20			0.787
E		8.5			0.335	
e		2.54			0.100	
e3		15.24			0.600	
F			7.1			0.280
I			5.1			0.201
L		3.3			0.130	
Z	1.27		2.54	0.050		0.100

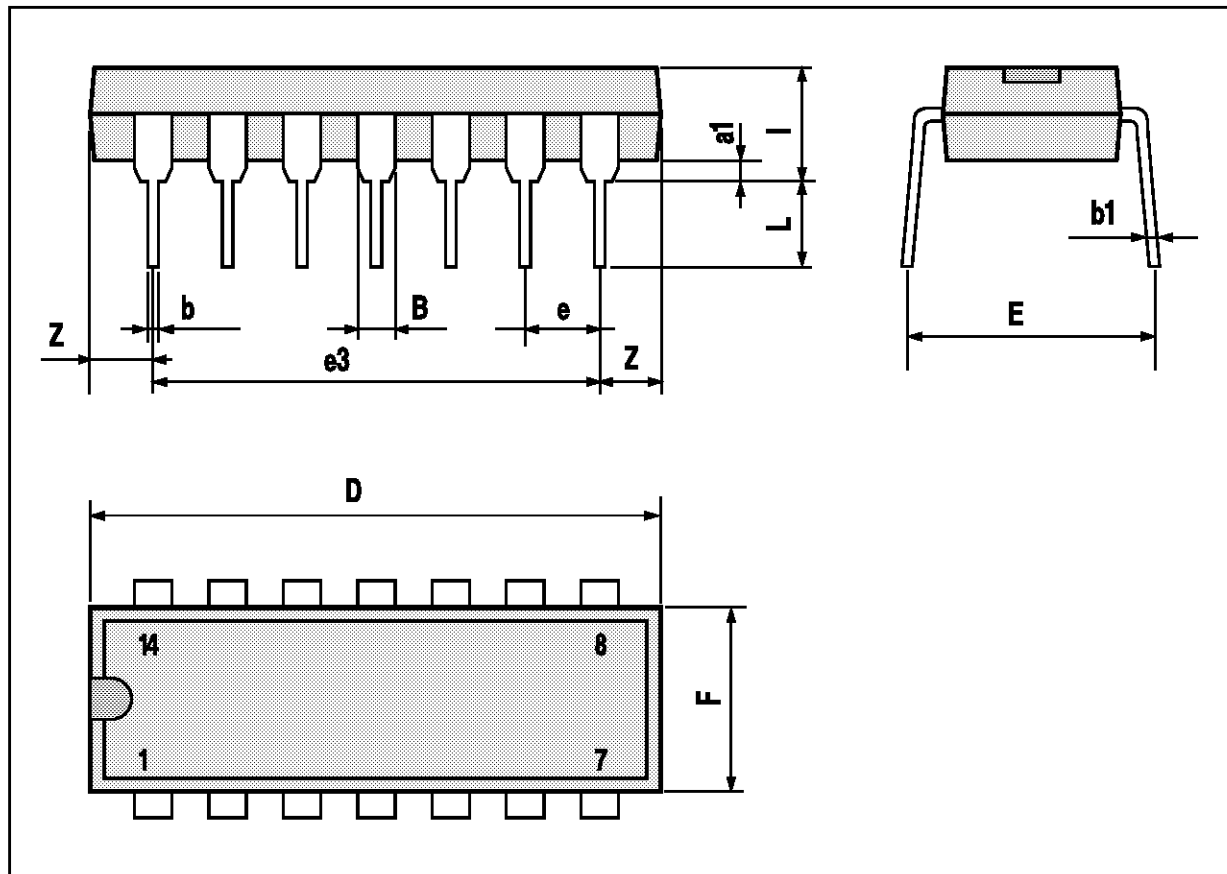

SO14 PACKAGE MECHANICAL DATA

DIM.	mm			inch		
	MIN.	TYP.	MAX.	MIN.	TYP.	MAX.
A			1.75			0.069
a1	0.1		0.25	0.004		0.009
a2			1.6			0.063
b	0.35		0.46	0.014		0.018
b1	0.19		0.25	0.007		0.010
C		0.5			0.020	
c1	45 (typ.)					
D	8.55		8.75	0.336		0.344
E	5.8		6.2	0.228		0.244
e		1.27			0.050	
e3		7.62			0.300	
F	3.8		4.0	0.15		0.157
L	0.4		1.27	0.016		0.050
M			0.68			0.027
S	8 (max.)					

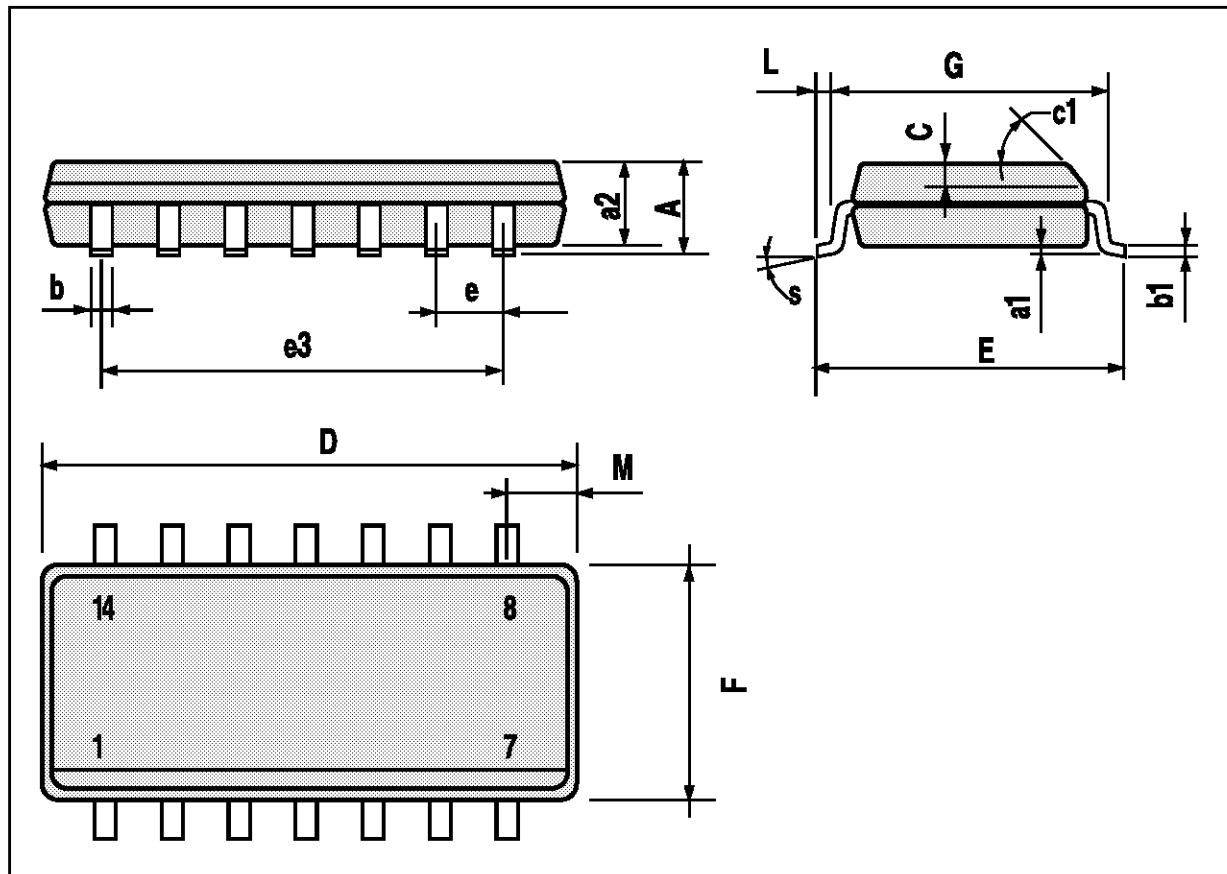

Information furnished is believed to be accurate and reliable. However, SGS-THOMSON Microelectronics assumes no responsibility for the consequences of use of such information nor for any infringement of patents or other rights of third parties which may result from its use. No license is granted by implication or otherwise under any patent or patent rights of SGS-THOMSON Microelectronics. Specifications mentioned in this publication are subject to change without notice. This publication supersedes and replaces all information previously supplied. SGS-THOMSON Microelectronics products are not authorized for use as critical components in life support devices or systems without express written approval of SGS-THOMSON Microelectronics.

© 1994 SGS-THOMSON Microelectronics - All Rights Reserved

SGS-THOMSON Microelectronics GROUP OF COMPANIES

Australia - Brazil - France - Germany - Hong Kong - Italy - Japan - Korea - Malaysia - Malta - Morocco - The Netherlands - Singapore - Spain - Sweden - Switzerland - Taiwan - Thailand - United Kingdom - U.S.A.